



Figure 1. Top View

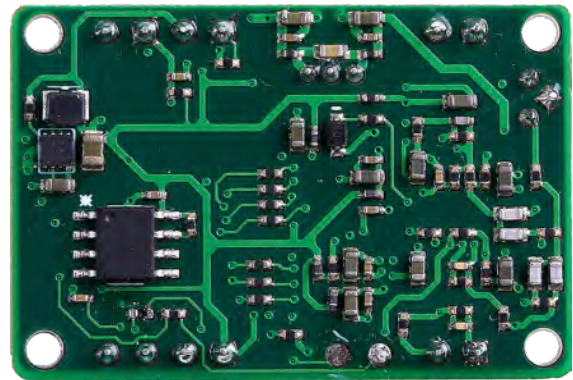

Figure 2. Bottom View

Feature

- MZM bias control on Q+ and Q- modes
- Low profile: 37mm(W) × 25mm(D) × 8mm(H)
- Typical Second Order Distortion¹ : -60dB
- Low dither amplitude: 2% V_{π}
- High stability: with fully digital implementation
- Easy to use:
 - Manual operation with mini jumper
 - Flexible OEM operations through UART²
- Two different modes to provide bias voltage:
 - a. Automatic bias control
 - b. User defined bias voltage

Application

- LiNbO₃ and other MZ modulators
- Digital NRZ, RZ
- CATV Transmitter
- Analog Link, RoF transmitter

Ordering Information

Part No.:MBC-Q-03

Contact: info@plugtech.hk

Telephone: +86 13790119725, +852 66459366

Introduction

PlugTech Precision Systems' modulator bias controller is specially designed for Mach-Zehnder modulators to ensure stable operations in various operating environments. Based on its fully digitized signal processing method, the controller can provide ultra stable performance.

The controller injects a low frequency, low amplitude dither signal together with a bias voltage into the modulator. It keeps reading the output from the modulator and determines the condition of the bias voltage and the related error. A compensate bias voltage will be applied afterwards according to the previous measurements. In this way, the modulator is ensured to work under a proper bias voltage.

The controller is very compact in volume, and is suitable for modern communication systems.

¹ Second order distortion at low frequency range (from 0 to 100kHz) is typical below -68dB. At 70MHz is typical -55dB.

² UART operation is only available on some version of the controller.

Specifications

Parameter	Min	Typ	Max	Unit
Control Performance				
CSO ¹	-55	-65	-70	dBc
Stabilization time		10		s
Electrical				
Positive power voltage	+14.5	+15	+15.5	V
Positive power current	15		30	mA
Negative power voltage	-15.5	-15	-14.5	V
Negative power current	1.5		4	mA
Output voltage range	-11.34		+11.34	V
Output voltage precision		350		μV
Dither frequency	999.95	1000.00	1000.05	Hz
Dither amplitude		2% V_{π}		V
Optical				
Input optical power ²	-30		-9	dBm
Input wavelength	1100		1650	nm

¹ CSO refers to composite second order. To measure CSO correctly, the linear quality of RF signal, modulators and receivers shall be ensured. In addition, the system CSO readings may vary when running at different RF frequencies.

² Please be noted that the input optical power does not correspond to the optical power at the selected bias point. It refers to the maximum optical power that the modulator can export to the controller when the bias voltage ranges from $-V_{\pi}$ to $+V_{\pi}$.



Figure 3. Controller with adaptor

User Interface

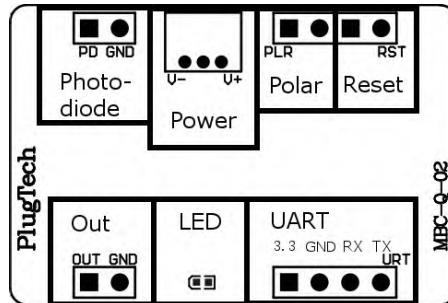

Figure 4. Assembly

Group	Operation	Explanation
Photodiode ¹	PD: Connect MZM photodiode's Cathode	Provide photocurrent feedback
	GND: Connect MZM photodiode's Anode	
Power	Power source for bias controller	V-: connects the negative electrode
		V+: connects the positive electrode
		Middle probe: connects the ground electrode
Polar ²	Insert or pull out the jumper	no jumper: Q+ mode; with jumper: Q- mode
Reset	Insert jumper and pull out after 1 second	Reset the controller
Out	Connect with the MZM bias voltage port	OUT and GND provide bias voltages for modulator
LED	Constantly on	Working under stable state
	On-off or off-on every 0.2s	Processing data and searching for controlling point
	On-off or off-on every 1s	Input optical power is too weak
	On-off or off-on every 3s	Input optical power is too strong
UART	Operate controller via UART	3.3: 3.3V reference voltage
		GND: Ground
		RX: Receive of controller
		TX: Transmit of controller

¹ Some MZ modulators have on board photodiodes. Only one choice shall be chosen between using controller photodiode or using modulator photodiode. It is recommended to use controller photodiode for Lab experiments for two reasons. Firstly, controller photodiode has ensured qualities. Secondly, it is easier to adjust the input light intensity. Note: If using modulator's internal photodiode, please make sure that the output current of photodiode is strictly proportional to input power.

² Polar depends on system RF signal. When there is no RF signal in the system, the polar should be positive. When RF signal has amplitude greater than a certain level, the polar will change from positive into negative. At this time, Null point and Peak point will switch with each other. Q+ point and Q- point will switch with each other as well. Polar switch enables user to change the polar directly without changing operation points

UART Command List

UART of the controller works at TTL(3.3V) level with following parameters: 57600 baud rate, 8 data bits, no parity bit, 1 stop bit.

Note: UART control is an additional feature for bias controller. Only those model number ended with 'A' (for example, MBC-Q-03A) support UART control.

Description	Command ID ¹	Data Send ¹	Data Received ²	Unit
Get optical power ³	0x67	NA	Current optical power ⁴	μ W
Get bias voltage	0x68	NA	Current bias voltage ⁴	V
Get V_{π}	0x69	NA	Modulator V_{π} ⁴	V
Set polar	0x6D	0x01: Positive	0x11: Success; 0x88: Error	
	0x6D	0x02: Negative	0x11: Success; 0x88: Error	
Set control mode	0x6B	0x01: automative control	0x11: Success; 0x88: Error	
	0x6B	0x02: manually set DAC	0x11: Success; 0x88: Error	
Set output voltage ⁵	0x6C	voltage ⁶	0x11: Success; 0x88: Error	
System Reset ⁷	0x6E	NA	NA	
Jump 2 V_{π} ⁸	0x6F	0x01: Forward ⁹	0x11: Success; 0x88: Error	
	0x6F	0x02: Backward ¹⁰	0x11: Success; 0x88: Error	
Get operating status ¹¹	0x70	NA	0x01: Stabilizing	
	0x70	NA	0x02: Stabilized	
	0x70	NA	0x03: Light too weak	
	0x70	NA	0x04: Light too strong	
	0x70	NA	0x05: Manual state	
Set Offset ¹²	0x71	voltage ¹³ +sign ¹⁴	0x11: Success; 0x88: Error	
Set Dither Amplitude ¹⁵	0x72	Dither Amplitude ¹⁶	0x11: Success; 0x88: Error	
Pause Control ¹⁷	0x73	NA	0x11: Success; 0x88: Error	
Resume Control ¹⁸	0x74	NA	0x11: Success; 0x88: Error	

¹ Bias controller can be controlled by a master device, such as a microprocessor, through UART. Command ID and Data Send refer to the data sent by master device. Each command should be send in a frame of 7 bytes following the sequence of Command ID(1 byte) + Data(6 bytes). For data bytes, it should be filled from the first byte and unused data bytes should be zero.

² Data received refer to the data received by master device. For data received, it has a frame of 9 bytes following the sequence of Command ID(1 byte)+Data(8 bytes). Similar to data send, received data bytes will be filled from the first byte and unused data bytes will be filled with zero.

³ The average power corresponds to the optical power which inputs into the controller. The responsivity used in calculation is 0.85A/W.

⁴ Data received is 4 byte floating point number(Little Endian).

⁵ Set output voltage function can only be used when bias controller is working under manual mode.

⁶ Two byte, from 0x0000 to 0xFFFF. Calculation formula is

$$V_{bin} = \frac{V_{out} - V_{min}}{V_{max} - V_{min}} \times 65536$$

Where V_{bin} is the two byte binary that represent the output voltage, V_{out} is the actual output voltage, V_{max} and V_{min} is the maximum and minimum output voltage of the controller.

⁷ Reset the controller. It will start from initialization.

⁸ Modulators may have several working point seperated by $2V_{\pi}$. There may be difference in performance among all the working points. This function is designed to help user select among all the working points to find the best one.

Note: it may take around 5 seconds for the controller to settle after each jump.

⁹ Suppose current working point at V_1 . After jumping forward, the new working point is set at $V_1 + 2V_{\pi}$

¹⁰ Suppose current working point at V_1 . After jumping backward, the new working point is set at $V_1 - 2V_{\pi}$

¹¹ There might be a delay not exceeding 3s between the controller receives this command and send back data when the controller is in stabilizing status.

¹² Sets an offset from Q point of modulator. Suppose current working point is at V_1 and an offset of +0.5V is set. The new working point is $V_1 + 0.5$

¹³ Two bytes. This voltage is represented by multiple of DAC step. For example, if the offset voltage is 1000, the actual working voltage will be Q point working voltage + 1000 DAC steps. DAC step is calculated by the following formula:

$$V_{step} = \frac{V_{max} - V_{min}}{65536}$$

¹⁴ One byte. 1 represent negative sign and 2 represent positive sign. For example, if [0x03 0xE8 0x02] is sent to controller, controller will add 1000 DAC steps to current working point.

¹⁵ Set dither amplitude. It can only be the multiple of $0.1\%V_{\pi}$ and maximum dither amplitude is 2%. For example, if dither amplitude of arm I is set to be 3. Then dither amplitude on arm I will be 0.3%

¹⁶ Format of the data is dither amplitude. Only one byte.

¹⁷ This function will pause the controller's automatic control. Dither will be stopped and bias voltage output will remain at the value when the pause command is executed.

¹⁸ This function is used together with Pause Control. When pause control is executed and the automatic control is needed, executing this command will resume automatic control.

Environmental Characteristics

Parameter	Min	Typ	Max	Unit
Operating temperature	-10		50	°C
Storage temperature	-20		80	°C

Dimensions

Parameter	Value
Dimensions (W × D × H)	37mm × 25mm × 8mm
Weight	100g

Typical Application

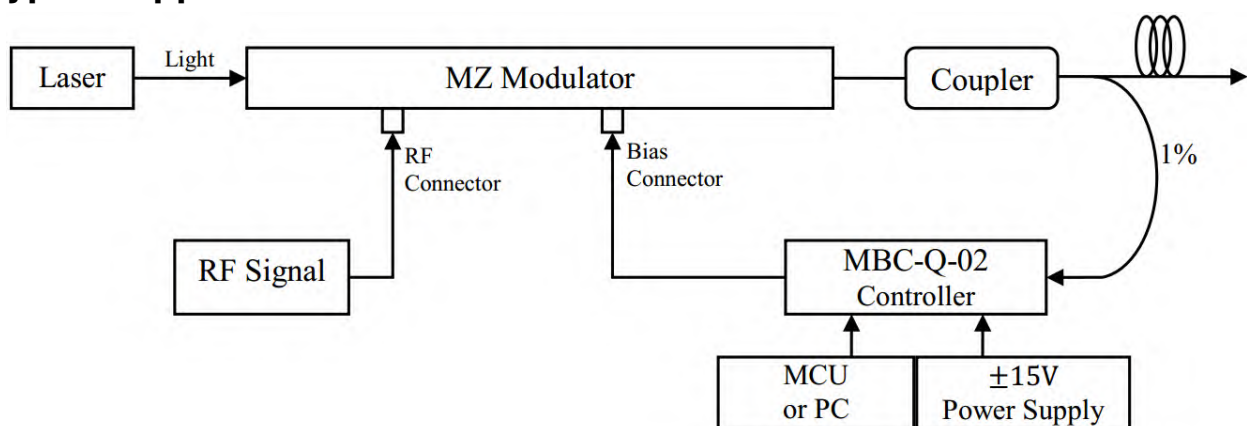

The controller is easy to use.

Step1. Connect 1% port of the coupler to the photodiode of the controller.

Step2. Connect bias voltage output of the controller (through SMA or 2.54mm 2-pin header) to bias port of the modulator.

Step3. Provide controller with +15V and -15V DC voltages.

Step4. Reset the controller and it will start to work.

NOTE. Please be ensured that RF signal of the whole system is on before resetting the controller.



This is an electrostatic-sensitive device. Please observe precautions for handling

**Content of the datasheet is subject to modification.
Please send an enquiry email to info@plugtech.hk for latest version of datasheet.**

Revision History

Version	Content	Date
1.0.0	First Release	2015-Apr
1.1.0	Minor modifications. Change pictures	2015-May
1.1.1	Modifications in UART section.	2015-Aug
1.1.2	Minor changes in typo mistake. Update part no. and picture	2015-Sep
1.1.3	Update UART section.	2015-Oct
2.0.0	Update to MBC-Q-02.	2015-Dec
2.0.1	Update UART section.	2015-Dec
2.0.2	Update UART settings description.	2016-Mar
2.0.3	Consolidate UART function description.	2016-May
2.0.4	Update current on specification table	2016-Sep
2.0.5	Update contact and part no.	2016-Oct
2.0.6	Add restriction on modulator's internal PD.	2016-Dec
2.0.7	Update UART section	2017-Mar