

MBC-MZM Controller Operating Instruction

(1) Product Structure

No.	Name	Describe
1	Photodiode	External Optical Feedback Input
2	Ca An pins	Modulator's Internal photodiode Input
3	Power Connector	Controller's power supply connector
4	RST Pin	Operation for resetting controller
5	MS Pin	Operation for mode selection
6	PLR Pin	Operation for polar selection
7	CS Pin	Operation for control method selection
8	3.3 Pin	3.3V reference voltage of UART interface
	GND TX RX Pins	UART interface for communication
9	OUT GND Pins	Controller's bias Output
10	M2 Mounting Hole	Controller's mounting hole
11	LED	Constantly on: Working under tracking state
		On-off or off-on every 0.2s: Initializing and searching for controlling point
		On-off or off-on every 1s: Controller's feedback input power is too weak
		On-off or off-on every 3s: Controller's feedback input power is too strong

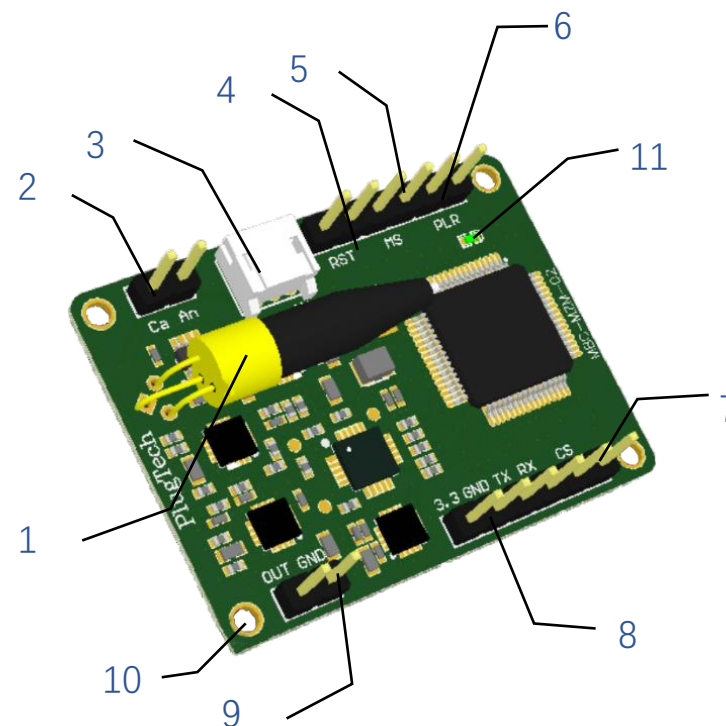

Figure1. Product Structure

(2) Product Operating and Storage Information

Parameter	Min	Typ	Max	Unit
Positive power voltage	+14.5	+15	+15.5	V
Positive power current	20		30	mA
Negative power voltage	-15.5	-15	-14.5	V
Negative power current	2		4	mA
Input optical power	-30		-5	dBm
Operating temperature	-10		50	°C
Storage temperature	-20		80	°C

(3) System Setup Instruction

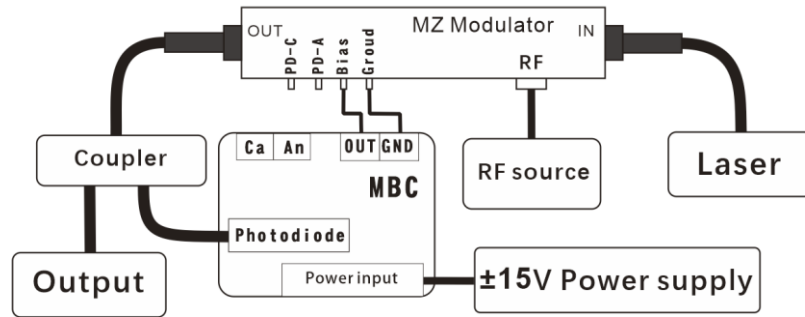

Figure 2. System diagram with controller's on-board photodiode

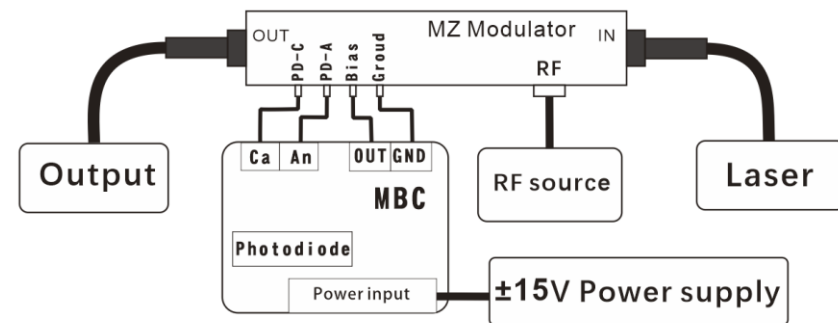

Figure 3. System diagram with modulator's internal photodiode

Depending on the different systems, the controller can be connected to the system as shown in Figure 2 or Figure 3. Here are the setup steps:

Step1. Setup controller's feedback input

Note: User should only choose one of the feedback method between controller's on-board photodiode or modulator's internal photodiode.

a) Using controller's on-board photodiode as feedback input:

Choose an appropriate optical coupler to ensure the controller's feedback optical power is within the range indicated in the Product Operating Information table. For example, if the laser output power is 10dBm and the modulator's insertion loss is 5dB, then the maximum optical output of the modulator is about 5dBm. In this situation, user can choose a 1:99 coupler and the 1% port output power is about -15dBm, which is within the range of controller's input range. Then user can connect the 1% port to controller's on-board photodiode as feedback input and the 99% port is the system's output.

b) Using modulator's internal photodiode as feedback input:

- Connect modulator's **PD-C (Photodiode Cathode)** pin to controller's Ca pin.
- Connect modulator's **PD-A (Photodiode Anode)** pin to controller's An pin.

Step2. Controller's output connection

- Connect controller's **OUT** pin to modulator's DC **Bias** pin
- Connect controller's **GND** pin to modulator's **Ground** pin

Step3. Controller's power connection

- Note: V+ connect to +15V DC supply, V- connect to -15V DC supply
- Controller can be turned on after the RF source and laser output is stable.
- After the controller is turned on, if the LED is lighted, that means the controller starts to work.

(4) Operating manual

<ul style="list-style-type: none">● Set MBC-MZM to work in NULL point<ol style="list-style-type: none">(1) Connect controller's output and feedback input properly(2) Keep MS pins and PLR pins not connected(3) Turn on or reset the controller	<ul style="list-style-type: none">● Set MBC-MZM to work in Q- point<ol style="list-style-type: none">(1) Connect controller's output and feedback input properly(2) Insert jumper between PLR pins. Insert jumper between MS pins(3) Turn on or reset the controller
<ul style="list-style-type: none">● Set MBC-MZM to work in Peak point<ol style="list-style-type: none">(1) Connect controller's output and feedback input properly(2) Keep MS pins not connected. Insert jumper between PLR pins(3) Turn on or reset the controller	<ul style="list-style-type: none">● Set MBC-MZM to work in Q+ point<ol style="list-style-type: none">(1) Connect controller's output and feedback input properly(2) Keep PLR pins not connected. Insert jumper between MS pins(3) Turn on or reset the controller
<ul style="list-style-type: none">● Controller Reset: Insert jumper and pull out after 1 second	
<ul style="list-style-type: none">● UART Command Control (Optional, available for Version A) :<ol style="list-style-type: none">(1) Connect controller's output and feedback input properly.(2) Use UART accessories to connect the controller to PC as shown in Figure4.(3) Turn on bias controller.(4) Use GUI software or Matlab script to operate the UART function.	 <p>The diagram illustrates the UART connection setup. On the left, a box labeled 'MBC' has three pins: GND, RX, and TX. On the right, a box labeled 'PC' has a USB port. In the center, an FT232RL module is shown with pins for RX, TX, and GND. Wires connect the MBC's GND to the FT232RL's GND, the MBC's TX to the FT232RL's TX, and the MBC's RX to the FT232RL's RX. A USB cable connects the FT232RL's USB port to the PC's USB port.</p>

Figure 4. UART Connection

(5) Cautions

- Do not reverse the V+ and V- power pins, otherwise it will cause permanent damage to the controller.
- ESD sensitive, please pay attention to human static electricity when operating.
- Please provide the correct power supply voltage to avoid interfering with the operation of the controller or damaging it.
- It is recommended that the ripple of the power supply be less than 120mV.
- Please turn on the bias controller after the laser and RF output are stable.

(6) PowerBoard Operation Instruction (Optional)

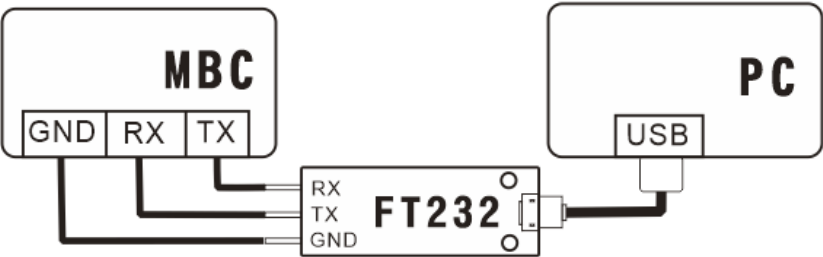
(1) Production Instruction

标识	名称	描述
1	M2 Mounting Hole	Powerboard's Mounting Hole
2	OUTPUT	Output voltage $\pm 15V$
3	Switch	Control Powerboard's Status
4	LED	Show Powerboard's Status
5	EARTH pin	Ground pin
6	INPUT1	+5V Input1
7	Input selection port	Connection between input 1 and + 5V: INPUT1 as the input Connection between input 2 and + 5V: INPUT2 as the input
8	INPUT2	+5V Input2

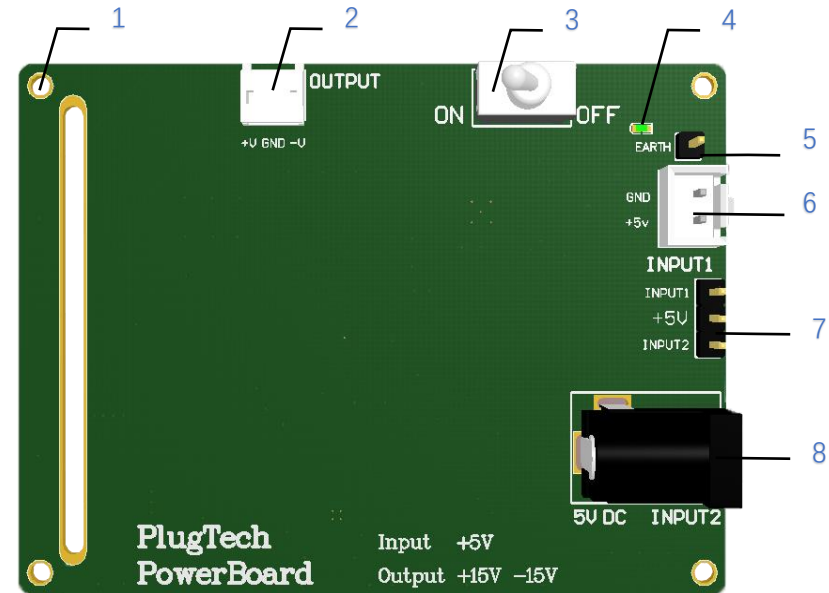

(2) Operation manual

Step1: Choose Input Port (User should only choose one of the input port between INPUT1 and INPUT2)

1. Choose INPUT1

- Insert jumper between +5V pin and INPUT1 pin.
- Provide +5V voltage for INPUT1.

2. Choose INPUT2

- Insert jumper between +5V pin and INPUT2 pin.
- Connect the adapter's output to INPUT2.

Step2: Powerboard's output connection

- Connect powerboard's output to controller's supply connector.

Step3: turn on Powerboard

- Turn the switch to the "ON" direction. if the LED is lighted, that mean powerboard start to work.

Version	Content	Date
1.0.0	First Release	2020/11/11
1.0.1	Add powerboard's operation Instruction	2021/1/12