

# Ultra Compact DP-IQ Modulator Bias Controller MBC-DPIQ-02

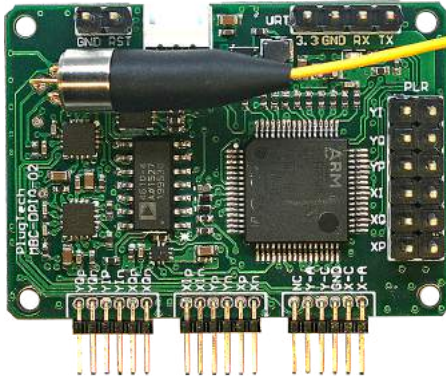

Figure 1. Top View

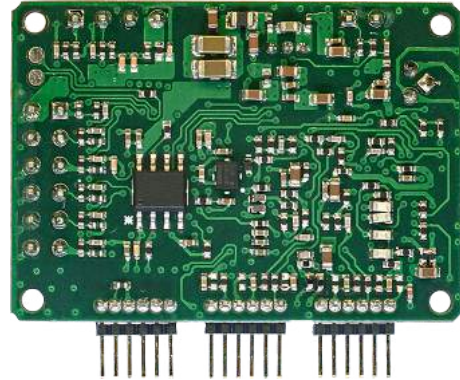

Figure 2. Bottom View

## Feature

- Simultaneously provides six automatic bias voltages for Dual Polarization IQ modulators
- Modulation format independent: SSB, QPSK, QAM, OFDM verified.
- Plug and Play: No manual calibration needed Everything automatic
- I, Q arms: controll on Peak and Null modes High extinction ratio:50dB max<sup>1</sup>
- P arm: controll on Q+ and Q- modes Accuracy:  $\pm 2^\circ$
- Low profile: 40mm(W)  $\times$  29mm(D)  $\times$  8mm(H)
- High stability: fully digital implementation
- Easy to use: Manual operation with mini jumper Flexible OEM operations through UART<sup>2</sup> /IO
- Two modes to provide bias voltages:
  - a. Automatic Bias Control
  - b. User defined bias voltage

## Application

- LiNbO<sub>3</sub> and other DP-IQ modulators
- Coherent Transmission

## Ordering Information

Part No.: MBC-DPIQ-02

Contact: info@plugtech.hk

Telephone: +86 13790119725, +852 66459366

## Introduction

A DP-IQ modulator consists of two IQ modulators and a polarization rotator. Each IQ modulator consists of three different modulators: I, Q arms are intensity modulators, P arm is a phase modulator. The DP-IQ modulator is typically applied to DP-QPSK systems. Plugtech Precision Systems' modulator bias controller is specially designed for DP-IQ modulators to ensure stable operations in various operating environments. Based on its fully digitized signal processing method, the controller can provide ultra stable performance.

The controller injects a low frequency, low amplitude dither signal together with a bias voltage into the modulator. It keeps reading the output from the modulator and determines the condition of the modulator and the related error. A compensate bias voltage will be applied afterwards according to the previous measurements. In this way, the DP-IQ modulator is ensured to work under a proper bias voltage.

The controller is very compact in volume, and is suitable for modern communication systems.

<sup>1</sup> The highest extinction ratio depends on and cannot exceed 1 the system modulator maximum extinction ratio.

<sup>2</sup> UART operation is only available on some version of the controller.

Performance

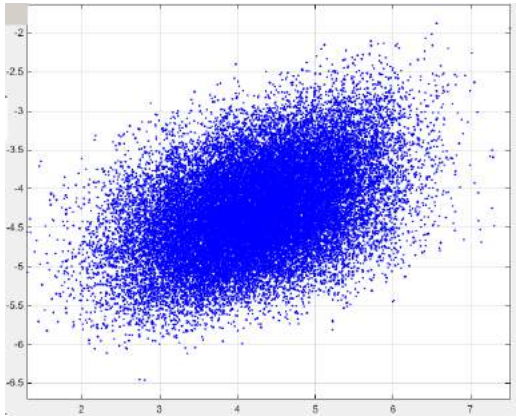

Figure 3. QPSK Constellation pattern (without controller)

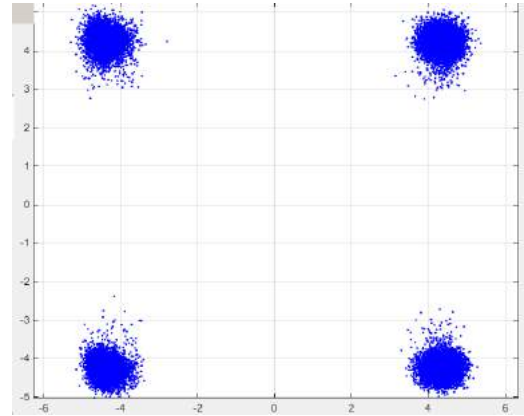

Figure 4. QPSK Constellation pattern (with controller)

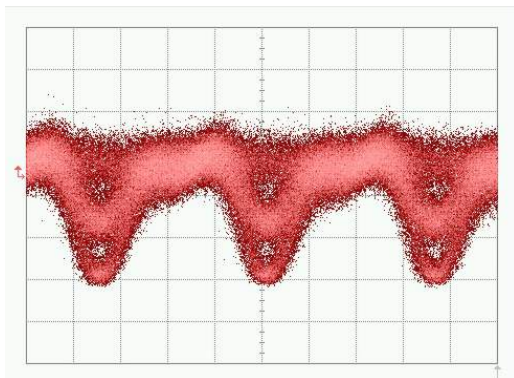

Figure 5. QPSK-Eye pattern

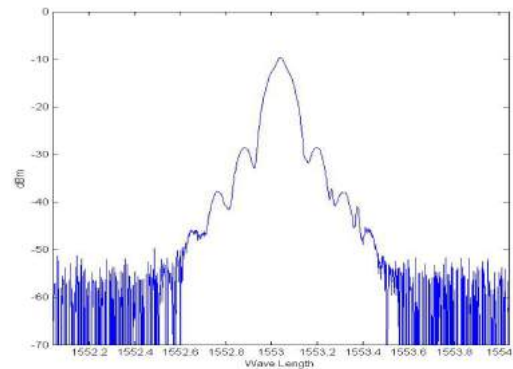

Figure 6. QPSK-Spectrum pattern

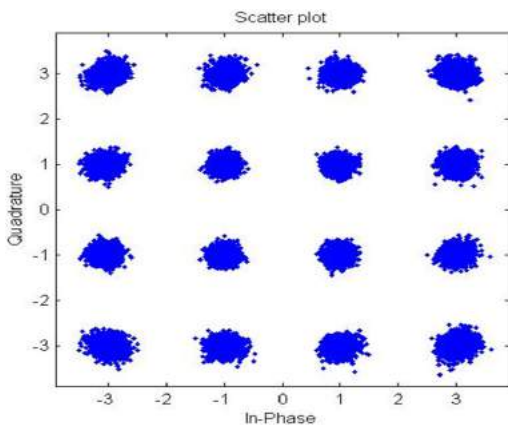

Figure 7. 16-QAM Constellation pattern

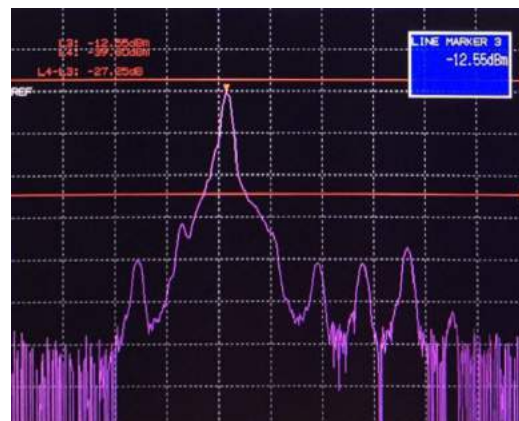

Figure 8. CS-SSB Spectrum

## Specifications

Parameter	Min	Typ	Max	Unit
<b>Control Performance</b>				
I, Q arms are controlled on <b>Null(Minimum)</b> or <b>Peak(Maximum)</b> point				
Extinction ratio		MER <sup>1</sup>	50	dB
P arm is controlled on <b>Q+(right quadrature)</b> or <b>Q-( left quadrature)</b> point				
Accuracy at Quad	-2		+2	degree <sup>2</sup>
Stablization time	45	50	55	s
<b>Electrical</b>				
Positive power voltage	+14.5	+15	+15.5	V
Positive power current	20		30	mA
Negative power voltage	-15.5	-15	-14.5	V
Negative power current	8		15	mA
Output voltage range of YI/YQ/XI/XQ	-14.5		+14.5	V
Output voltage range of YP/XP	-13		+13	V
Dither amplitude		1%V <sub>π</sub>		V
<b>Optical</b>				
Input optical power <sup>3</sup>	-30		-8	dBm
Input wavelength	1100		1650	nm

<sup>1</sup> MER refers to intrinsic Modulator Extinction Ratio. The extinction ratio achieved is typically the extinction ratio of the modulator specified in modulator datasheet.

<sup>2</sup> Let  $V_{\pi}$  denote the bias voltage at  $180^{\circ}$  and  $V_P$  denote the most optimized bias voltage at Quad points. Then the controller bias voltage output will be in the range of:  $V_P \pm \frac{2^{\circ}}{180^{\circ}} V_{\pi}$

<sup>3</sup> Please be noted that the input optical power does not refer to the optical power at the selected bias point. It is the maximum optical power that the modulator can export to the controller when the bias voltage ranges from  $-V_{\pi}$  to  $+V_{\pi}$ .



**Figure 9. Product with adaptor**

## User Interface

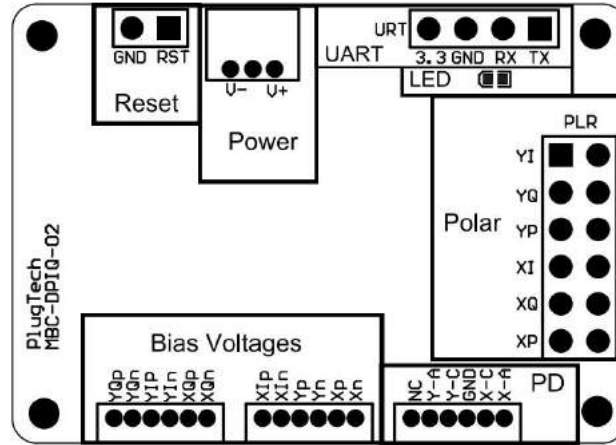

Figure 10. Assembly

Group	Operation	Explanation
Rest	Insert jumper and pull out after 1 second	Reset the controller
Power	Power source for bias controller	V- connects the negative electrode of the power supply
		V+ connects the positive electrode of the power supply
		Middle port connects with the ground electrode
UART	Operate controller via UART	3.3: 3.3V reference voltage
		GND: Ground
		RX: Receive of controller
		TX: Transmit of controller
LED	Constantly on	Working under stable state
	On-off or off-on every 0.2s	Processing data and searching for controlling point
	On-off or off-on every 1s	Input optical power is too weak
	On-off or off-on every 3s	Input optical power is too strong
Polar <sup>1</sup>	PLR-XI: Insert or pull out the jumper	no jumper: Null mode; with jumper: Peak mode
	PLR-XQ: Insert or pull out the jumper	no jumper: Null mode; with jumper: Peak mode
	PLR-XP: Insert or pull out the jumper	no jumper: Q+ mode; with jumper: Q- mode
	PLR-YI: Insert or pull out the jumper	no jumper: Null mode; with jumper: Peak mode
	PLR-YQ: Insert or pull out the jumper	no jumper: Null mode; with jumper: Peak mode
	PLR-YP: Insert or pull out the jumper	no jumper: Q+ mode; with jumper: Q- mode
Bias Voltages	YQp, YQn: Bias for Y polarization Q arm	YQp: Positive side; YQn: Negative side or ground
	YIp, YIn: Bias for Y polarization I arm	YIp: Positive side; YIn: Negative side or ground
	XQp, XQn: Bias for X polarization Q arm	XQp: Positive side; XQn: Negative side or ground
	XIp, XIn: Bias for X polarization I arm	XIp: Positive side; XIn: Negative side or ground
	YPp, YPn: Bias for Y polarization P arm	YPp: Positive side; YPn: Negative side or ground
	XPp, XPn: Bias for X polarization P arm	XPp: Positive side; XPn: Negative side or ground

<sup>1</sup> Polar depends on system RF signal. When there is no RF signal in the system, the polar should be positive. When RF signal has amplitude greater than a certain level, the polar will change from positive into negative. At this time, Null point and Peak point will switch with each other. Q+ point and Q- point will switch with each other as well. Polar switch enables user to change the polar directly without changing operation points.

## MBC-DPIQ-02

Group	Operation	Explanation
PD <sup>1</sup>	NC: Not Connected	
	Y-A: Y-polarization photodiode Anode	Y-A and Y-C: Y polarization photocurrent feedback
	Y-C: Y-polarization photodiode Cathode	
	GND: Ground	
	X-C: X-polarization photodiode Cathode	X-A and X-C: X polarization photocurrent feedback
	X-A: X-polarization photodiode Anode	

<sup>1</sup> Only one choice shall be chosen between using controller photodiode or using modulator photodiode. It is recommended to use controller photodiode for Lab experiments for two reasons. Firstly, controller photodiode has ensured qualities. Secondly, it is easier to adjust the input light intensity. If using modulator's internal photodiode, please make sure that the output current of photodiode is strictly proportional to input power.

## UART Command List

UART of the controller works at TTL(3.3V) level with following parameters: 57600 baud rate, 8 data bits, no parity bit, 1 stop bit.

**Note: UART control is an additional feature for bias controller. Only those model number ended with 'A' (for example, MBC-DPIQ-01A) support UART control.**

Description	Command ID <sup>1</sup>	Data Send <sup>1</sup>	Data Received <sup>2</sup>	Unit
Get optical power <sup>3</sup>	0x65	NA	Current optical power <sup>4</sup>	$\mu$ W
Get bias voltage	0x66	Arm <sup>5</sup>	Current bias voltage <sup>4</sup>	V
Get $V_{\pi}$	0x67	Arm <sup>5</sup>	Modulator $V_{\pi}$ <sup>4</sup>	V
Get polar	0x68	NA	Current polar of controller <sup>6</sup>	
Get operating status <sup>7</sup>	0x69	NA	Controller operating status <sup>8</sup>	
Set control mode	0x6A	Control mode <sup>9</sup>	Status <sup>10</sup>	
Set output voltage <sup>11</sup>	0x6B	Arm <sup>5</sup> + Voltage <sup>12</sup>	Status <sup>10</sup>	
Set polar	0x6C	Polar <sup>13</sup>	Status <sup>10</sup>	
System reset <sup>14</sup>	0x6D	NA	NA	
Set Dither Amplitude <sup>15</sup>	0x6F	Dither Amplitude <sup>16</sup>	Status <sup>10</sup>	
Pause Control <sup>17</sup>	0x73	NA	Status <sup>10</sup>	
Resume Control <sup>18</sup>	0x74	NA	Status <sup>10</sup>	

<sup>1</sup> Bias controller can be controlled by a master device, such as a microprocessor, through UART. Command ID and Data Send refer to the data sent by master device. Each command should be sent in a frame of 7 bytes following the sequence of Command ID(1 byte) + Data(6 bytes). For data bytes, it should be filled from the first byte and unused data bytes should be zero.

<sup>2</sup> Data received refer to the data received by master device. For data received, it has a frame of 9 bytes following the sequence of Command ID(1 byte)+Data(8 bytes). Similar to data send, received data bytes will be filled from the first byte and unused data bytes will be filled with zero.

<sup>3</sup> The average power corresponds to the optical power which inputs into the controller.

<sup>4</sup> Data received is 4 byte floating point number(Little Endian).

<sup>5</sup> Arm of the IQ modulator. (0x01: Arm Y-I; 0x02: Arm Y-Q; 0x03: Arm Y-P; 0x04: Arm X-I; 0x05: Arm X-Q; 0x06: Arm X-P)

<sup>6</sup> Six bytes will be received. Each byte represents polar of one arm. Byte one is polar of arm Y-I, byte two is polar of arm Y-Q and byte three is polar of arm Y-P. Byte four, five and six are the polar for X-I, X-Q and X-P respectively.

<sup>7</sup> There might be a delay not exceeding 3s between the controller receives this command and send back data when the controller is in stabilizing status.

<sup>8</sup> Received data is one byte long. (0x01: Stabilizing; 0x02: Stabilized; 0x03: Light too weak; 0x04: Light too strong; 0x05: Manual state)

<sup>9</sup> Control mode is one byte. (0x01: Auto Control; 0x02: Manual Control)

<sup>10</sup> One byte. (0x11: Success; 0x88: Error)

<sup>11</sup> Set output voltage function can only be used when bias controller is working under manual mode. Due to the accuracy and non-linearity of DAC, there is an error not exceeding 20mV when using this function.

<sup>12</sup> Three bytes. For example, if 3.215V is required for output, the voltage should be multiplied by 1000 to convert the value to integer, i.e. 3215. Then convert 3215 to hex format. Hex format of 3215 is 0x0C8F. Byte one is the upper half of the final hex result, i.e. 0x0C. Byte two is the lower half, i.e. 0x8F. Byte three is sign of the voltage, 0x00 for positive, 0x01 for negative.

<sup>13</sup> Six bytes. These bytes are used to represent polar of arm Y-I, Y-Q, Y-P and X-I, X-Q, X-P. (0x01: Positive; 0x02: Negative)

<sup>14</sup> Reset the controller. It will start from initialization.

<sup>15</sup> Set dither amplitude on arm YI, YQ, XI and XQ. It can only be the multiple of 1% $V_{\pi}$  and maximum dither amplitude is 20%. For example, if dither amplitude of arm YI is set to be 3. Then dither amplitude on arm YI will be 3%. The amplitude's factory default value is 1, when user set a new value to the controller, it will be stored in Flash memory and

## MBC-DPIQ-02

automatically loaded when the controller is turned on or reset.

<sup>16</sup> Four bytes. Format of the data is dither amplitude YI + dither amplitude YQ + dither amplitude XI + dither amplitude XQ. One byte for each arm.

<sup>17</sup> This function will pause the controller's automatic control. Dither will be stopped and bias voltage output of arm I,Q and P will remain at the value when the pause command is executed.

<sup>18</sup> This function is used together with Pause Control. When pause control is executed and the automatic control is needed, executing this command will resume automatic control.

# MBC-DPIQ-02

## Environmental Characteristics

Parameter	Min	Typ	Max	Unit
Operating temperature	-10		50	°C
Storage temperature	-20		80	°C

## Dimension

Parameter	Value
Dimensions (W×D×H)	40mm×29mm×8mm
Weight	100g

## Typical Application

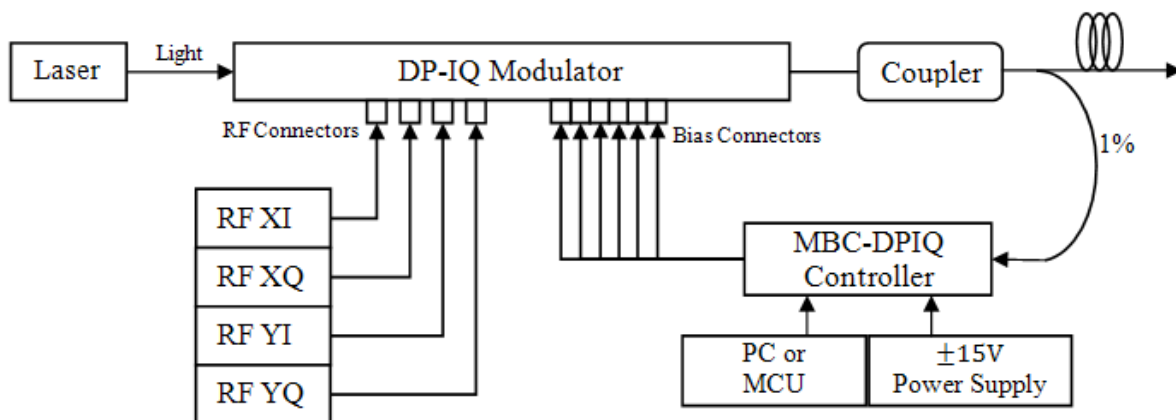

The controller is easy to use.

**Step1.** Connect 1% port of the coupler to the photodiode of the controller.

**Step2.** Connect bias voltage outputs of the controller(through 1.27mm or 2.54mm header) with bias port of the modulators (XI, XQ, XP; YI, YQ, YP).

**Step3.** Provide controller with +15V and -15V DC voltages.

**Step4.** Insert the jumper and pull out after 1 second, the controller will be reseted and start to work.

**NOTE 1.** Please be ensured that RF signal of the whole system is on before resetting controller.

**NOTE 2.** If the controller indicates the input light is too weak or too strong, the input light intensity shall be adjusted. After adjustment, controller shall be restarted to ensure proper operation.





**This is an electrostatic-sensitive device. Please observe precautions for handling**

**Content of the datasheet is subject to modification.  
Please send an enquiry email to [info@plugtech.hk](mailto:info@plugtech.hk) for latest version of datasheet.**

**Revision History**

<b>Version</b>	<b>Content</b>	<b>Date</b>
1.0.0	First Release	2015-Dec
1.0.1	Add UART settings description	2016-Mar
1.0.2	SSB performance pictures added; board assembly modified	2016-Jun
1.0.3	Current on specification table updated	2016-Sep
1.0.4	Contact updated	2016-Oct
1.0.5	More accurate description of limitation of internal photodiode of modulator, update output bias voltage range.	2016-Dec
1.0.6	Update UART section	2017-Mar
1.0.7	Update Part No. and UART section	2017-Aug
1.0.8	Update User Interface Description	2020-Feb
1.0.9	Update UART Command and Note	2020-May